

# DURAT<sup>®</sup> CUSTOMISED SURFACES

Tools for architects and designers

## Contents

Usage	2
The structure of a Durat top	2
Standard sink sizes	4
structure	4
oval	7
round	8
rectangular	9
Customised shower tray	14

**DURAT<sup>®</sup>**

**[www.durat.com](http://www.durat.com)**

## DURAT<sup>®</sup> USAGE

DURAT offers designers almost infinite opportunities to create various surfaces. DURAT sheets can be used to create for example coherent, jointless surfaces tens of metres in length with various forms of edge designs and intarsia patterns. The seams can be sanded down to make them almost invisible. The standard sheet size is 2900 x 800 x 12 mm.

DURAT is extremely durable and easy to keep clean, and the surfaces can be renewed by sanding if necessary.

### THE STRUCTURE OF A DURAT<sup>®</sup> TOP

The standard thickness of a DURAT sheet is 12 mm. When making a DURAT top the sheet is backed up by a 12-18 mm thick plywood or MDF support. The visible edges are finished in DURAT. The standard edge of a worktop is 30 mm high, but the edge height can also be different. The edge radius can be specified. If not specifically defined the standard radius is 2 mm.

Upstand can be made into any height.  
The standard radius is 8mm.

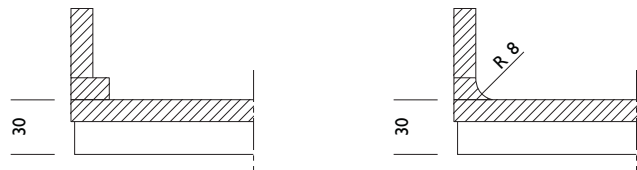

Standard DURAT top with 50 mm upstand.

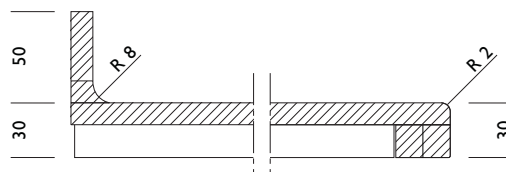

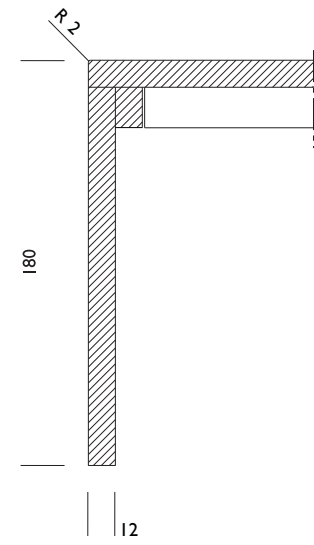
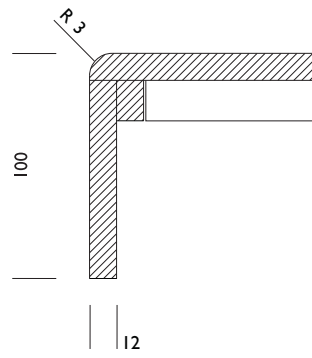
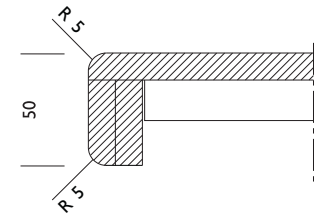
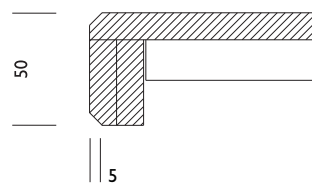
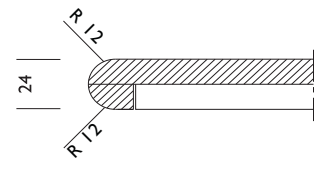
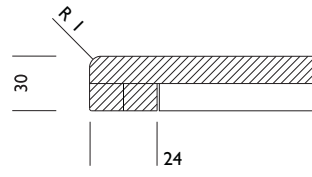
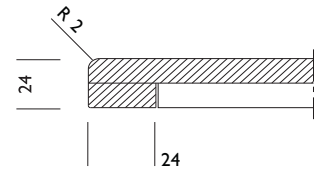
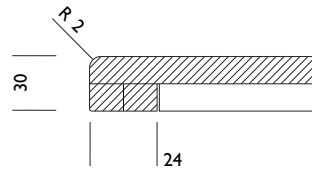

## DURAT<sup>®</sup> STANDARD SINK SIZES

DURAT offers an extensive set of standard sinks - round, oval and rectangular - to be used in custom made vanity units for bathrooms and public sanitary facilities.

The standard sinks can be attached to a top of more or less any length and width, and the top can incorporate several sinks. The sinks are attached to the top from below to make up one entity. When attached to a top the inner depth of the sink will increase by the sheet thickness 12 mm.

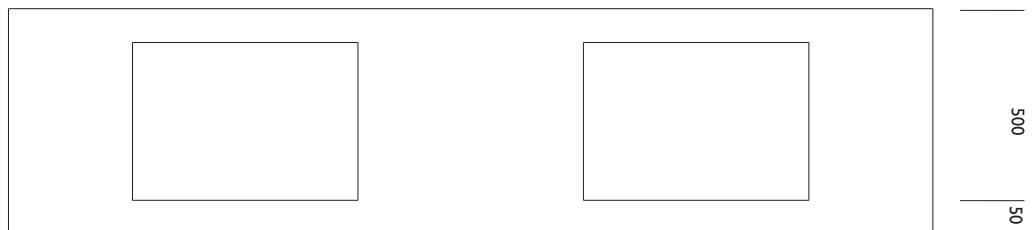
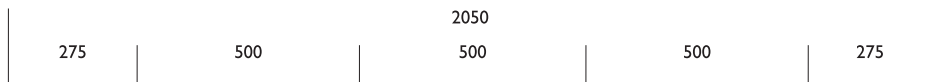
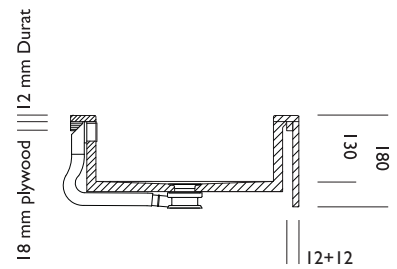



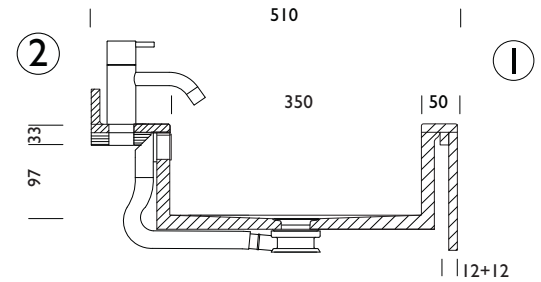
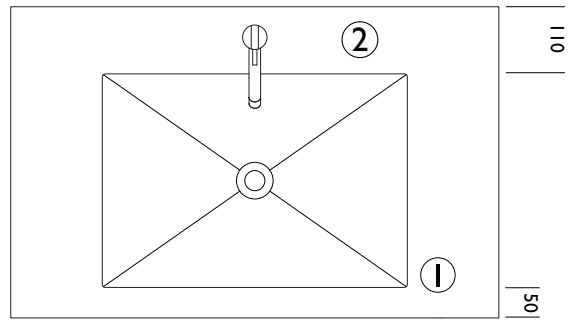

Section with tap and overflow

Durat top placed on furniture

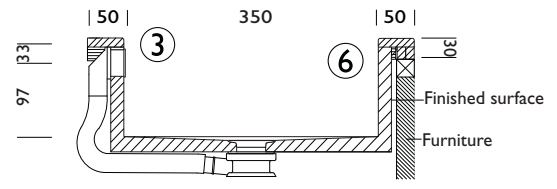

Section with overflow

Durat top wallmounted with stainless steel support structure

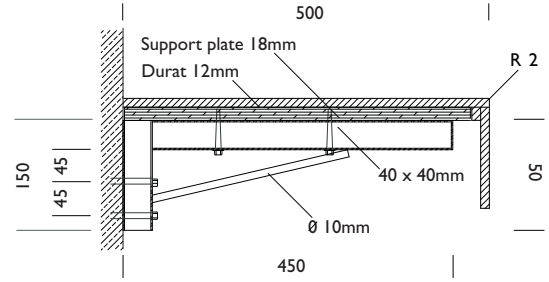

Section of stainless steel structure

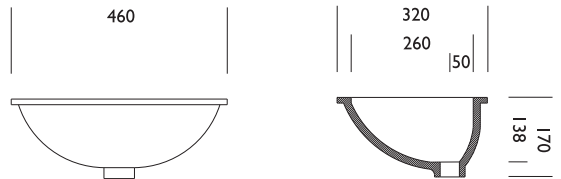
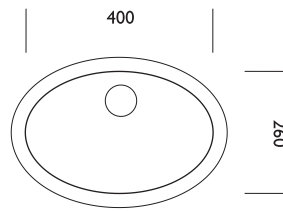

**oval I** 400 x 260 x 138 (+12) mm

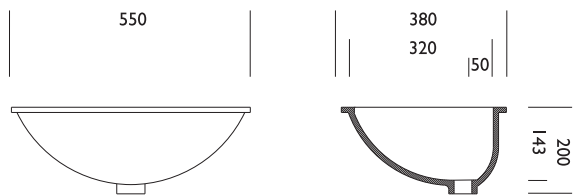
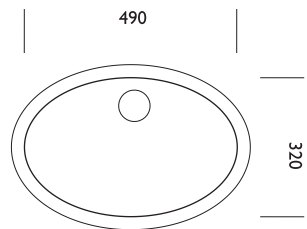

**Oval II** 490 x 320 x 143 (+12) mm

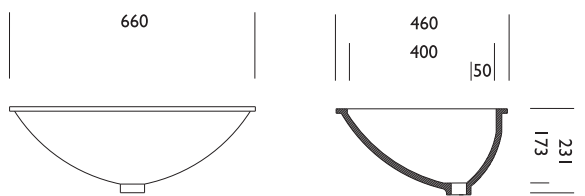
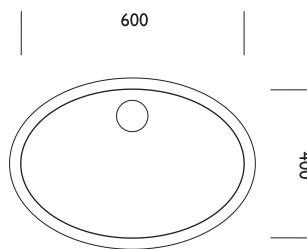

**Oval III** 600 x 400 x 173 (+12) mm

**Round I**  $\varnothing 300 \times 118 (+12)$  mm

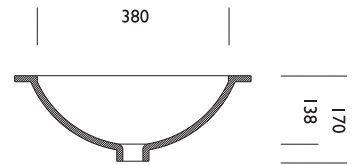
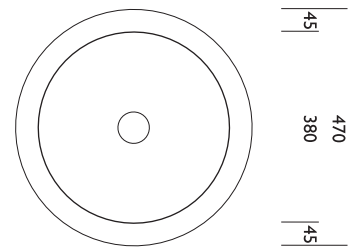
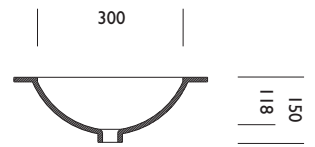
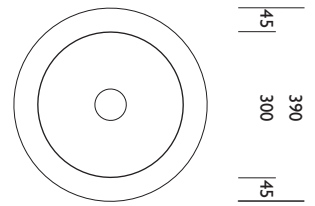

**Round II**  $\varnothing 380 \times 138 (+12)$  mm

**Rectangular I** 340/350 × 230 × 118 (+12) mm

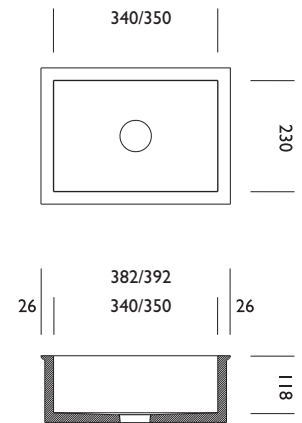

**Rectangular II** 480 × 230 × 118 (+12) mm

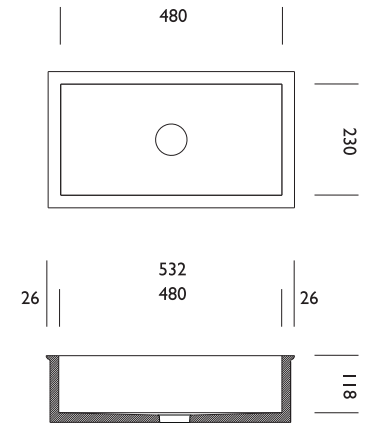

**Rectangular III** 400 × 350 × 118 (+12) mm

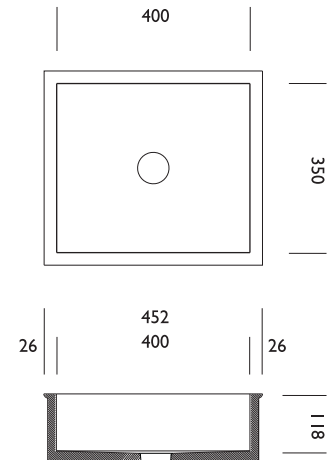

**Rectangular III (Kitchen)** 400 x 350 x 188 (+12) mm

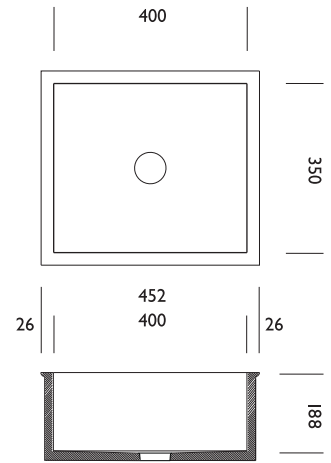

**Rectangular IV** 500 x 300 x 118 (+12) mm

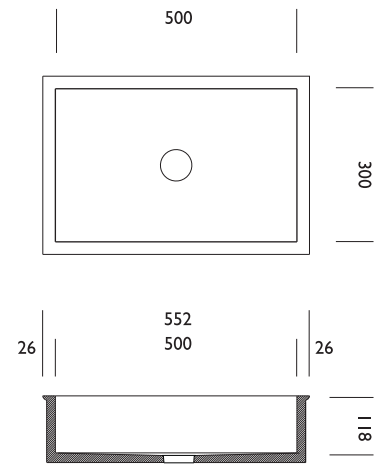

**Rectangular V** 500 x 350 x 118 (+12) mm

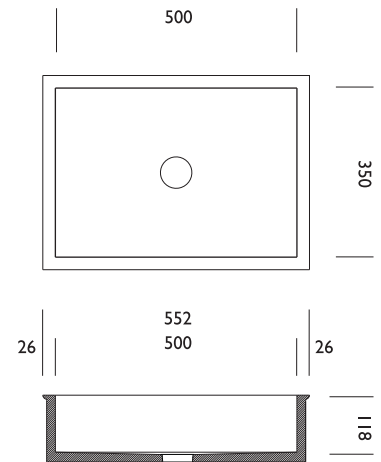

**Rectangular VI KEHTO**  
 510 x 320 x 138 (+12) mm

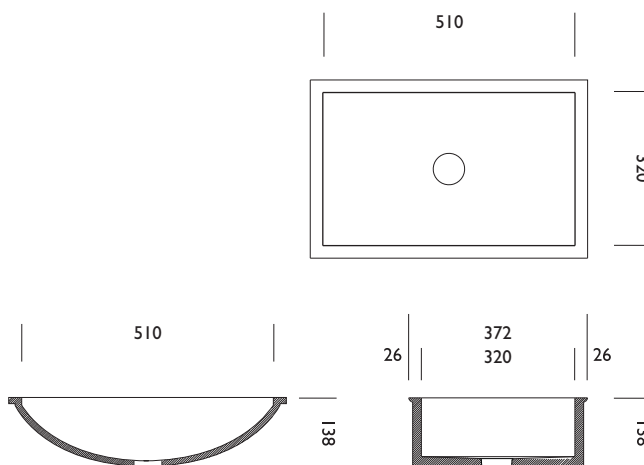

**Rectangular VII** 800 x 250 x 118 (+12) mm

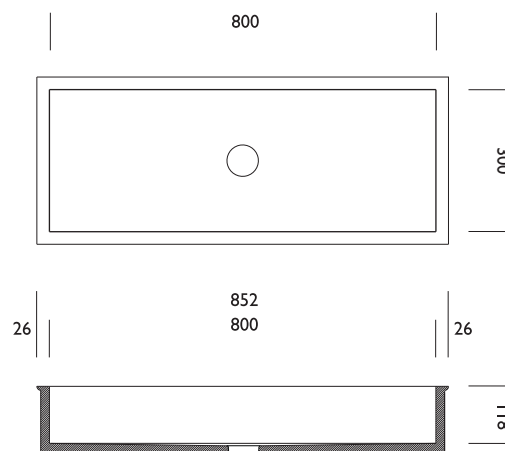
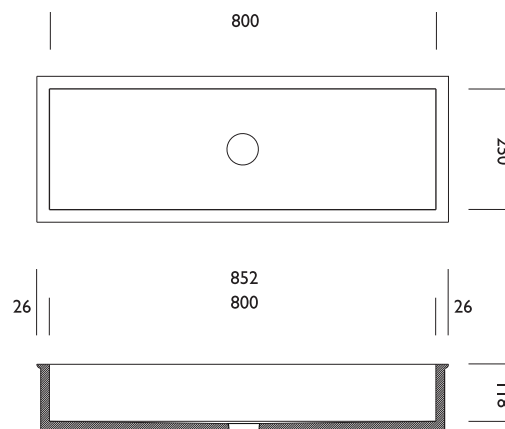

**Rectangular IX** 600 x 350 x 118 (+12) mm

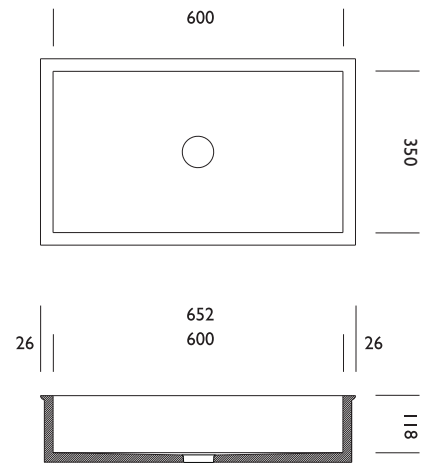

**Rectangular X** 600 x 400 x 118 (+12) mm

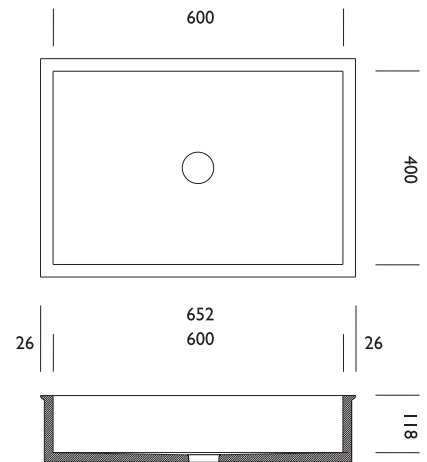

**Rectangular XI** 1100 x 350 x 118 (+12) mm

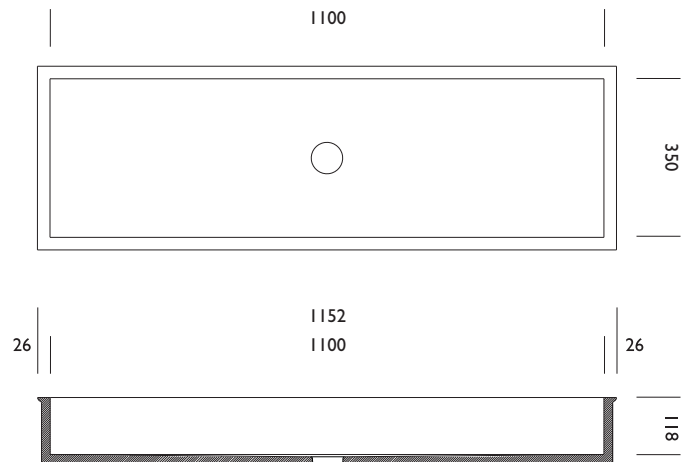

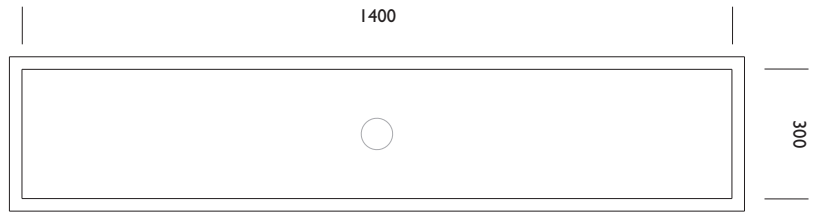

**Rectangular XII** 1400 x 300 x 118 (+12) mm

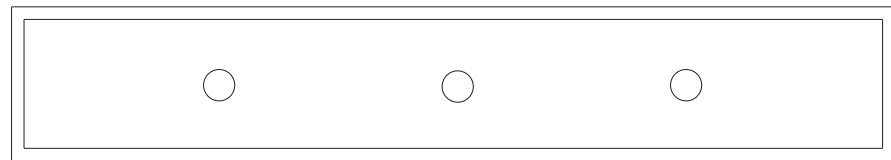
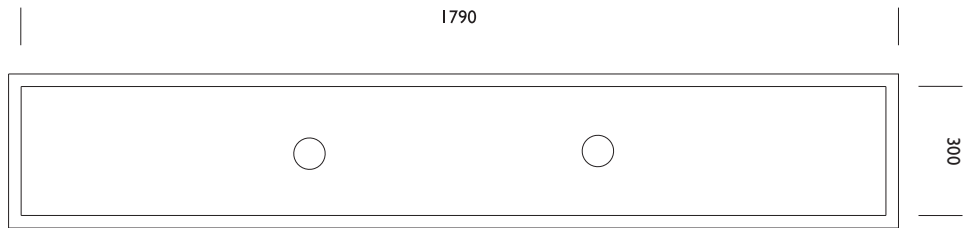
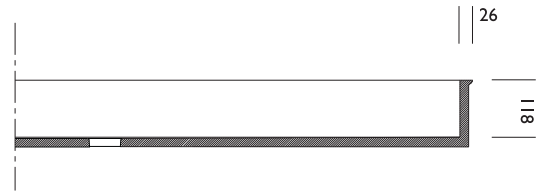

**Rectangular XIII** 1790 x 300 x 118 (+12) mm

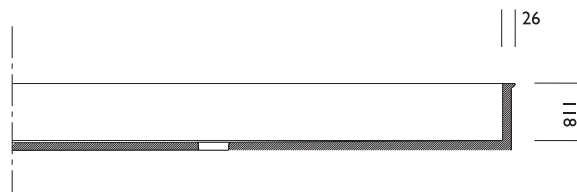

## BESPOKE WASH BASIN UNITS

For larger projects where there are several identical units needed (e.g. 50 or 100 pieces) there is the possibility of having a mould made for a bespoke wash basin with a customised sink size. For more details on this option please contact the manufacturer.

**DURAT<sup>®</sup>**

### CUSTOMISED SHOWER TRAY

The length and width of the Durat shower tray can be altered to make the tray fit a certain space.

The maximum dimensions of the customised shower tray are L 2000 x W 1000 mm.

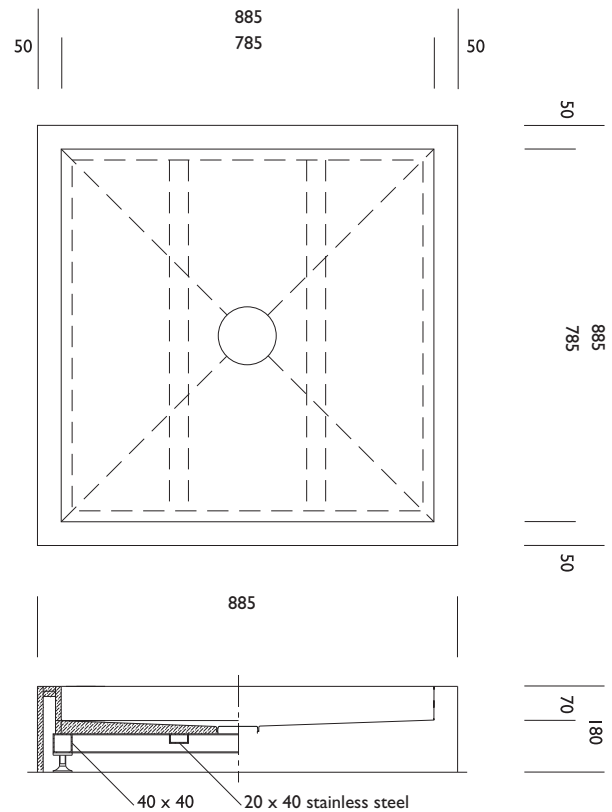

**Example 885 x 885 x 180 mm**